

TECHNICAL PARAMETERS Vibration exciter S 59416/AIT-590

Rated peak force $Sine_{pk}/Random_{RMS}/Shock_{pk}$ ¹	1 680 000/1 680 000/504 000 N
Frequency range	5-2000 Hz
Main resonance frequency	1700 Hz
Max. displacement Peak-Peak	50.8 mm
Max. velocity Sine/Random/Shock	2.0/2.0/3.0 m/s
Max. acceleration Sine/Random/Shock ¹	100/100/250 g
Suspension stiffness	250 N/mm
Effective moving mass	125 kg
Max. weight tested	1300 kg
Weight	8450 kg
Magnetic stray field	1.5 mT
Armature diameter	590 mm
Required compressed air supply	Min. 700 kPa
Interlocks	Temperature, displacement, water flow rate, differential pressure, overcurrent, compressed air, conductance

¹⁾ theoretical maximum shock value. Depends on payload, amplifier, shock and shock width

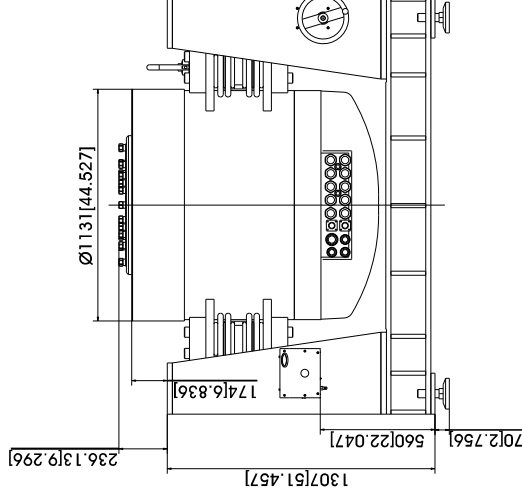

SCOPE OF DELIVERY, OPTIONS AND FEATURES OF THE SYSTEM

Scope of delivery:	Features:
Vibration exciter 168 kN	Vibration isolation < 3 Hz (AIT)
Swivel frame with integrated vibration isolation (AIT)	Fully automatic pneumatic load compensation
Power amplifier 293 kVA	Frictionless hydrostatic bearing (Dual Bearing)
Cooling unit with integrated hydraulic unit	AIT fixable the armature
Connection cables (each 10 m)	Automatic centering of the AIT-System and the armature
Power cables (each 10 m) for amplifier (Direct connection)	Degauss kit to reduce stray magnetic field
Water hoses with self-sealing couplings (each 10 m)	Shaker-water circuit with overpressure
Hydraulic hoses with self-sealing couplings (each 10 m)	Automatic permanent monitoring of conductance
Compressed-air hose NW 7.2 (Standard) (10 m)	Integrated mains switch and line filter
	Noise-button
	Energy-saving-mode
	Input voltage analyzer
	Voltage clipping limiter to avoid clipping
	3 Sigma peak current
	Made in Germany
	Servicehotline (Monday-Friday)

Options:

- Different hole pattern of armature (different pitch diameter and/or thread inserts) at customers request
- Thermobarrier (-40°C to +140°C)
- Chamber leadthrough
- Climatic chamber support kit
- Remote control (Software)
- Cable/Hose extension
- Factory acceptance test

Features:

- Vibration isolation < 3 Hz (AIT)
- Fully automatic pneumatic load compensation
- Frictionless hydrostatic bearing (Dual Bearing)
- AIT fixable the armature
- Automatic centering of the AIT-System and the armature
- Degauss kit to reduce stray magnetic field
- Shaker-water circuit with overpressure
- Automatic permanent monitoring of conductance
- Integrated mains switch and line filter
- Noise-button
- Energy-saving-mode
- Input voltage analyzer
- Voltage clipping limiter to avoid clipping
- 3 Sigma peak current
- Made in Germany
- Servicehotline (Monday-Friday)

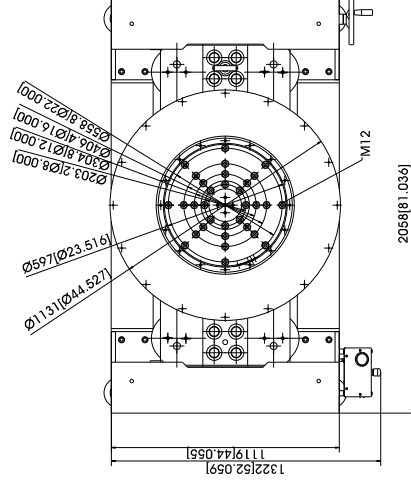

TECHNICAL PARAMETERS Power Amplifier A 5 85 3 293

Output power_{RMS}	293000 VA	Features:	High Signal to noise ratio of > 90 dB
Frequency range	DC - 4 kHz	Mains switch	Lo-Field/Hi-Field button (Energy-saving mode)
Voltage_{RMS} max.	150 V	Integrated field supply	ESD-monitoring (Protection of the system against damage)
Current_{RMS} max.	1950 A	1 Ohm	Noise-button
Load resistance, opt.	2.5/5/10 V	< 0.7 %	Input voltage analyzer
Signal input voltage_{RMS} (switchable)	> 90 dB	240 V	Voltage clipping limiter to avoid clipping
Distortion	2900 kg	355 A	3 Sigma peak current
Field voltage, max.	2840 x 2320 x 1050 mm	400 A slow	Field voltage/field current variable according to customer spec.
Field current, max.	3 ~ / N / PE 400 V ± 5% 50 Hz	Direct connection (terminal block)	
Weight	400 A slow	249 kVA	
Dimensions (WxHxD)	Overload, temperature, clipping and more		
Power supply (Standard)			
Recommended fuse protection (Standard)			
Max. power consumption at 400 V (incl. cooling unit)			
Interlocks:			



TECHNICAL PARAMETERS Cooling unit C 59430

Environmental conditions:		Features:	Closed system --> No pollution and no water loss by evaporation
Temperature	5 - 30 °C	The system works with a higher pressure --> No cavitation interferences at the measuring signal	Manometers and flow meters at several places within the circuits
Relative humidity	10 - 80 %	Integrated condensation monitoring and demineralisation	Fine filter with pollution monitoring
Energy transfer	max. 3 kW	Reduction of water consumption at part load by controlling of the process water flow	Self-sealing couplings (free from leakage)
Process water:		Optional: Hose length according to customer specs (up to 20 m)	Optional: Monitoring of all data, warnings and error messages at the PC
Temperature	5 - 15 °C		
Volume flow at max. supply temperature	24 m³/h		
Working pressure: supply - static	≤ 10 bar (≤ 1000 kPa)		
Working pressure: dynamic differential pressure	≥ 3 bar (≥ 300 kPa)		
Dissipated heat flow	max. 220 kW		
Nominal width of supply pipes	R 1 1/2 IT (40 mm)		
pH value	7 ± 1		
Dimensions of dirt particles	< 25 µm		
Water hardness (total/carbonate)	< 8 °dH / < 5 °dH		
Weight	620 kg		
Dimensions (WxHxD)	800 x 2140 x 1000 mm		

