

Calibration Vibration Test System TV 51110-AC

S 51110-AC (Example drawing) (mm)

TECHNICAL PARAMETERS Vibration exciter S 51110-AC

Rated peak force $Sine_{RMS}/Random_{RMS}$	100/50 N
Frequency range	DC-20000 Hz
Main resonance frequency	> 19000 Hz
Max. displacement Peak-Peak	25.4 mm
Max. velocity Sine/Random	1.2/1.2 m/s
Max. acceleration Sine/Random	17/8 g
Effective moving mass	0.53 kg
Weight	18 kg
Armature diameter	50 mm
Required compressed air supply	300 kPa (flow of app. 2.5 l/min)

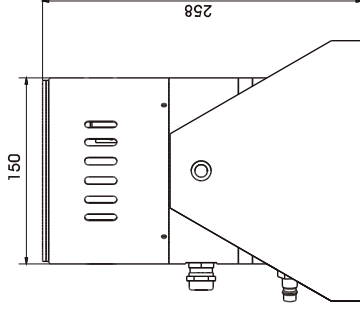

SCOPE OF DELIVERY, OPTIONS AND FEATURES OF THE SYSTEM

Scope of delivery:	Options:	Features:
Vibration exciter 100 N	Rack for mounting the amplifier	Vibration isolation
Swivel frame	Cable extension	Automatic centering of the armature
Power amplifier 500 VA	Factory acceptance test	High cross-axial stiffness
Electronic zero point regulation (Tira Middle Control=IMC)		Vibration system made of ceramic material
Connection cable (3 m)		Air bearing for frictionless and wear-free guidance
Power cable (1,5 m)		Minimum maintenance effort
Compressed-air hose NW 7,2 (Standard) (3 m)		Made in Germany
		Service hotline

TECHNICAL PARAMETERS Power Amplifier BAA 500-T

Output power _{RMS}	500 VA
Frequency range	DC - 20 kHz
Voltage-/Current mode	yes/no
Voltage _{RMS} max.	45 V
Current _{RMS} max.	11.2 A
Load resistance, opt.	4 Ohm
Signal input voltage _{RMS}	< 5 V
Distortion	< 0.1 %
Signal to noise ratio	> 90 dB
Weight (Amplifier+IMC)	29 kg
Dimensions (Amplifier+IMC, WxHxD)	483 x 170 x 450 mm
Power supply (Standard)	1 ~ / N / PE 230 V ± 5% 50 Hz
Recommended fuse protection (Standard)	CEE 7/7
Max. power consumption at 230 V	1.6 A slow
Interlocks:	0.35 kVA
	Overload, Temperature, Clipping

